

# Battery box PSU

## Bill of Materials:

- Battery box - - Walmart \$7.99
- Digital voltmeter - - eBay \$2 - \$4
- Switch, 12v, 20a - - Auto Zone; Mfr. Dorman p/n 85921, \$3.99
- Two (2) binding posts (preferably red and black), had in stock.
- Misc ¼" Faston quick connectors and ring lugs, had in stock.
- #12 or 14 AWG stranded wire; 6" of hookup wire.



Once I had the materials together, this project took a morning to complete.

Locate and mark the position of voltmeter, switch and binding posts on the removable top of the box. To me, the angled part of the top seemed best. There is plenty of clearance between the battery and the wiring and components inside the box.

I laid out the binding posts first, since they were the easiest. Just drill two holes and mount.

Locate the switch and mark for the rectangular opening. Drill four small holes at the corners so a coping saw can be inserted to cut the opening. The plastic cuts easily. File the opening until the switch clears and snaps in. could use an X-Acto knife as well.

Repeat above for the voltmeter.

Wire according to the below schematic. I was able to use #12 AWG for the "Mains" wiring, but #14 AWG will be fine for these short lengths.

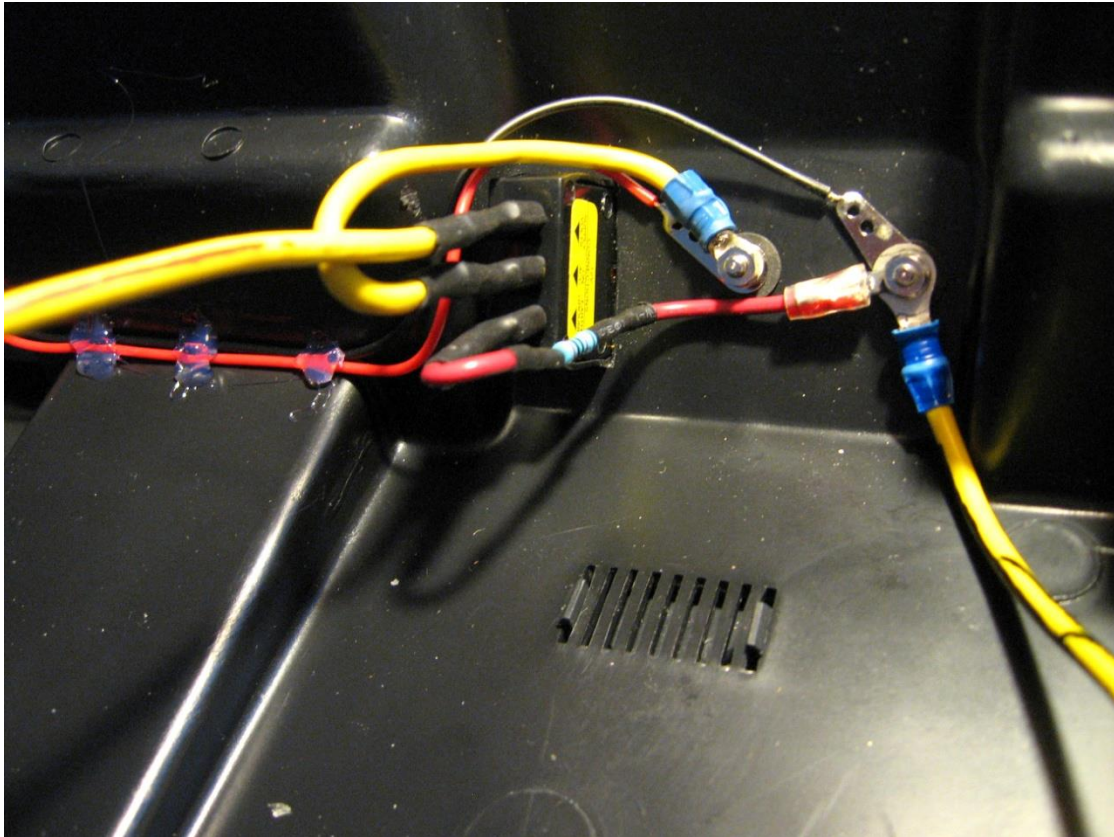
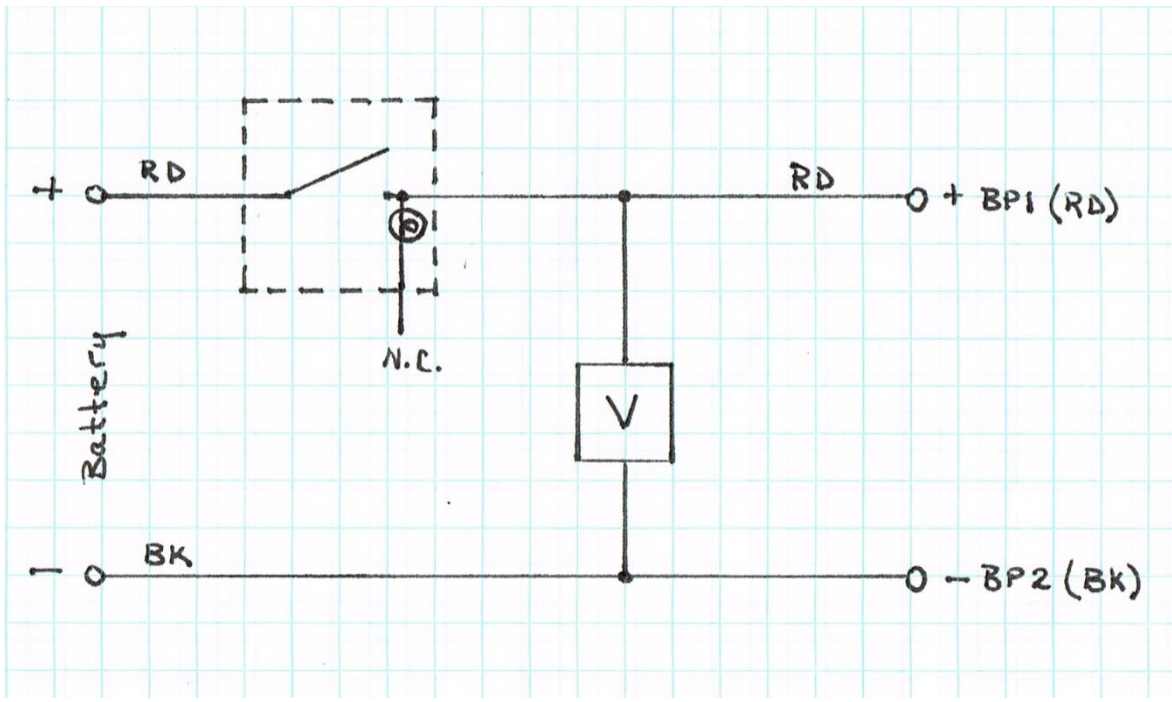

(Ignore resistor in the pic above)

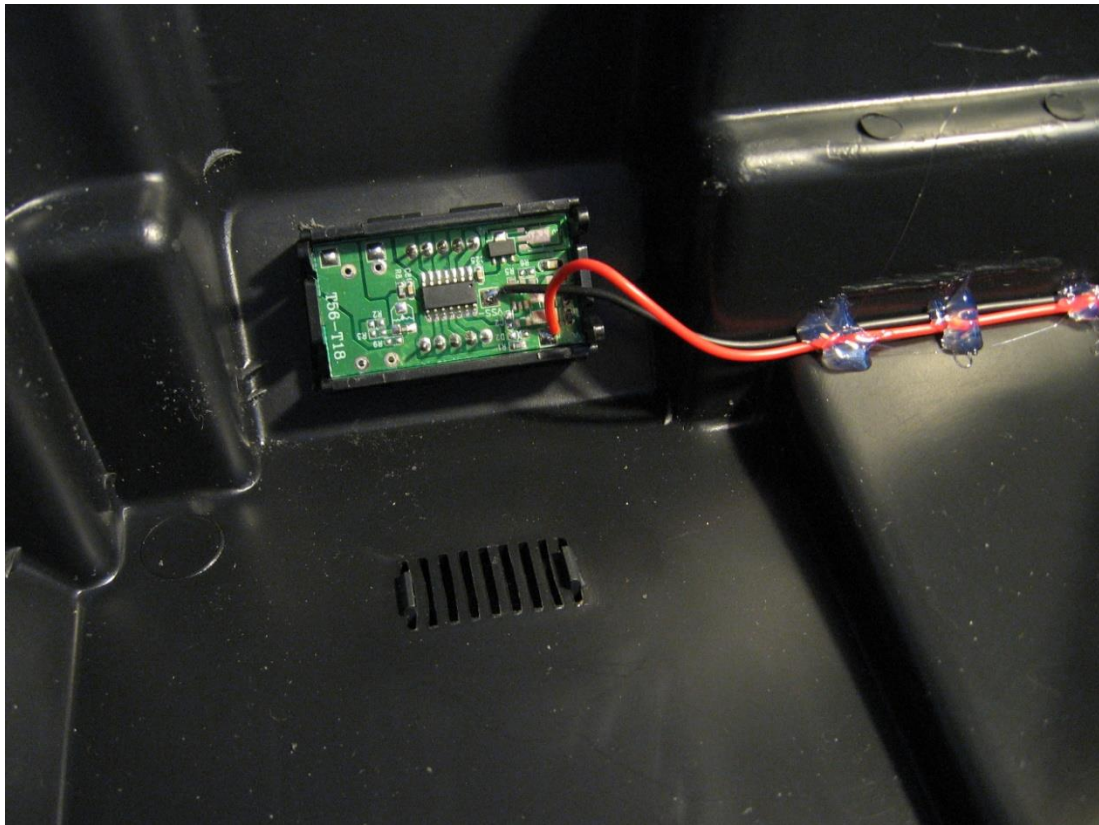

Use hot glue or some other sealant to dress voltmeter wires tight against the box cover.

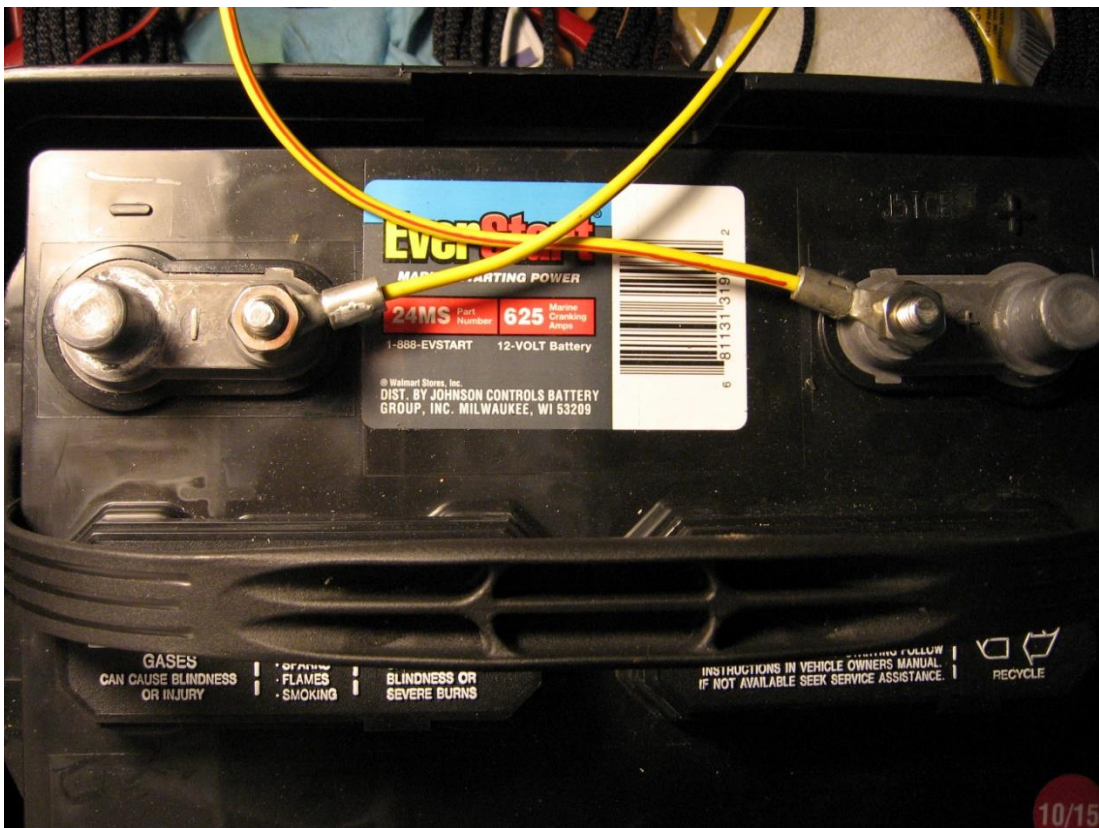

This battery, from Walmart, came with 5/16" studs. I had some large lugs but still had to enlarge the holes to fit. Suggestion: crimp AND solder these lugs. When not in use, a battery tender's clip leads can be affixed to the large posts.

Since there are many different types of transceiver power connections, I thought it best to use standard binding posts for output power. Users can then make short 6-inch adapter leads with spade or ring lugs on one end (battery side) and the connector(s) of choice on the other end, e.g., Molex, PowerPoles, ¼-inch Fastons, etc. These adapter leads can be made up and stored in a plastic bag\* and kept inside the battery compartment.

Note: When charging or otherwise not in use, suggest removing the top cover to allow air to circulate. This is why I made the battery leads about 18" long.

\* Necessary to help prevent corrosion from the battery fumes